

DELTA 7²⁰

TRANSMISSIVE WAVEFRONT MODULATOR

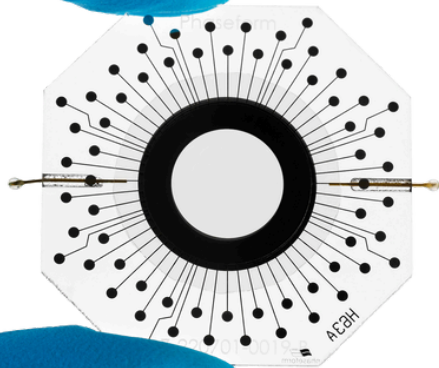

DPP TECHNOLOGY

The Delta 7²⁰ is based on Deformable Phase Plate (DPP) technology, exclusively developed by Phaseform GmbH. A DPP comprises a fluidic chamber enclosed by a thin membrane that is deformed by electrostatic force. This force is generated by a two-dimensional array of transparent electrodes embedded within the optical aperture of the DPP. The sophisticated optofluidic design of the DPP enables high-quality, real-time wavefront modulation in a fully refractive architecture.

KEY FEATURES

Complex wavefront modulation

63 electrodes enabling replication of up to the 7th radial order of Zernike polynomials (>35 modes) with high fidelity

Straightforward system integration

Compact housing compatible with the standard cage system with native M32 lens tube threading

Linear & hysteresis-free response

Electrostatic actuation suited for open-loop wavefront control

Remarkable optical quality

Active best flat with an induced RMS wavefront error of less than $\lambda/40$

Polarization-independent

Wavefront modulation independent of the light polarization for maximized efficiency



SPECIFICATIONS

GENERAL

Modulator type

Optofluidic DPP (Deformable Phase Plate),
electrostatically actuated, factory calibrated

Clear aperture diameter

20 mm

Number of actuators

63

Connectivity

USB 2.0

Included in the Delta 7 package

Driving electronics, control software, cables, manual

OPTICAL

Wavefront RMS error of best flat

< 15 nm (DPP horizontal, optical axis vertical)

Maximum peak-to-valley of the generated wavefronts

> 10 μm

Maximum spatial frequency of the correction

7th radial order of Zernike modes

Wavefront RMS drift

< 5% after 60 min

Laser Induced Damage Threshold (LIDT)

10 W/cm² for 10s @ 1070 nm CW

Optical transmission

Without AR coating



With AR coated membrane

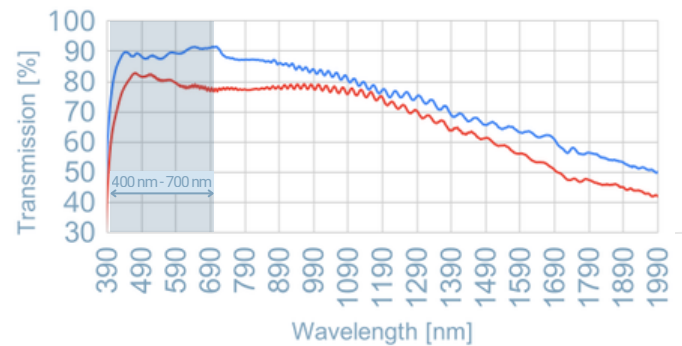

GENERATED ZERNIKE MODES IN OPEN LOOP

Max amplitude RMS, peak-to-valley, and purity of generated Zernike modes

Z (n,m)	RMS [μm]	PV [μm]	Purity [%]	Z (n,m)	RMS [μm]	PV [μm]	Purity [%]
Z (1,-1)	3	10	97	Z (5,3)	0.2	1.0	92
Z (1,1)	3	10	97	Z (5,5)	0.22	1.5	92
Z (2,-2)	1.3	5.0	98	Z (6,-6)	0.12	0.8	92
Z (2,0)	1.3	5.0	98	Z (6,-4)	0.12	0.8	92
Z (2,2)	1.3	5.0	98	Z (6,-2)	0.1	0.6	82
Z (3,-3)	0.6	3.1	95	Z (6,0)	0.1	0.6	82
Z (3,-1)	0.6	2.5	95	Z (6,2)	0.1	0.6	82
Z (3,1)	0.6	2.5	95	Z (6,4)	0.12	0.8	92
Z (3,3)	0.6	3.1	95	Z (6,6)	0.12	0.8	92
Z (4,-4)	0.35	2.0	94	Z (7,-7)	0.1	0.6	90
Z (4,-2)	0.35	1.5	94	Z (7,-5)	0.1	0.6	90
Z (4,0)	0.35	1.5	94	Z (7,-3)	0.07	0.5	70
Z (4,2)	0.35	1.5	94	Z (7,-1)	0.07	0.5	70
Z (4,4)	0.35	2.0	94	Z (7,1)	0.07	0.5	70
Z (5,-5)	0.22	1.5	92	Z (7,3)	0.07	0.5	70
Z (5,-3)	0.2	1.0	92	Z (7,5)	0.1	0.6	90
Z (5,-1)	0.2	1.0	92	Z (7,7)	0.1	0.6	90
Z (5,1)	0.2	1.0	92				

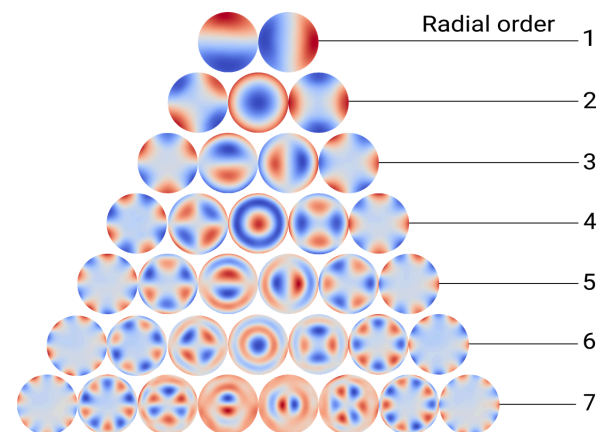

*Purity is defined as the fraction of the target Zernike mode relative to the root-square-sum of all modes.

**The Zernike-tree shows experimentally measured replicated Zernike modes up to the 7th order, in open-loop, using an interferometric setup.

SPECIFICATIONS, CONT.

MECHANICAL

- Thickness (within clear aperture)
- Response time (best flat to maximum deformation)
- Hysteresis
- Linearity
- Mounting orientation
- Mounting capability

- 0.87 mm
- < 40 ms
- < 1%
- > 92%
- Recommended horizontal only (optical axis vertical)
- Native M32 x 0.75 female threading, custom female to male thread adapters for other standard optics threads available upon request
- 1.5 m

ELECTRICAL

- Actuator voltage
- Maximum power consumption
- Power supply

- up to 295 V DC
- < 9 W
- 120/230 VAC

THERMAL

- Storage temperature
- Operating temperature

- 10 °C to 35 °C
- 20 °C to 25 °C

SOFTWARE

Graphical User Interface (GUI)

- Python-based interface using serial communication
- Direct application of phase profiles using Zernike polynomial descriptions

Software Development Kit (SDK)

- Python scripting control interface
- MATLAB wrappers to execute Python functions
- Easy integration into custom control software
- Reference implementation of the serial communication protocol included

Phinden (optional add-on for Delta 7)

- Turnkey software for real-time, image-based adaptive optics in microscopy
- Automated aberration correction improving resolution, SNR, and contrast
- Runs seamlessly alongside native microscope control software

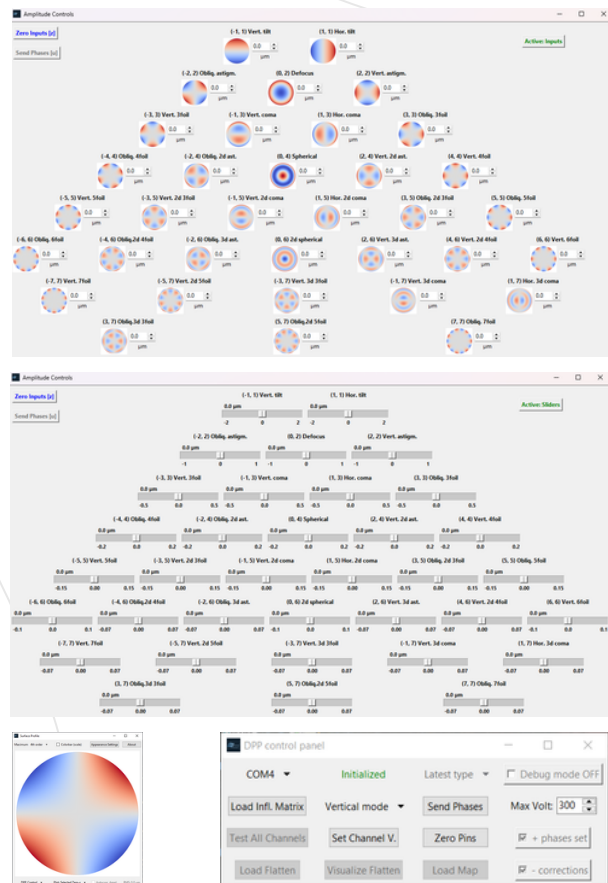

System Requirements

- Operating system: Windows, Linux, macOS
- Python: Minimum version 3.8, recommended - 3.11
- MATLAB: Minimum version R2020b

OPTICS HOUSING MECHANICAL DRAWINGS

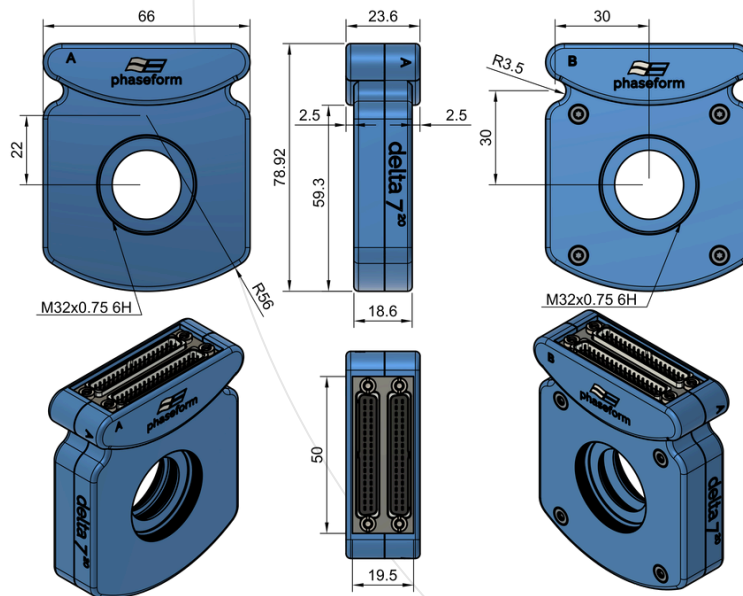

Weight: ~170 g

APPLICATION IDEA

Using a Delta 7¹⁰ in the excitation path of a light-sheet microscope to expand the effective field of view via modulating the Gaussian beam profile, and a Delta 7²⁰ in the detection path for wavefront coding to extend depth of field.

Courtesy of Prof. Pablo Loza-Alvarez and Dr. Gustavo Castro, SLN Lab, ICFO, Spain

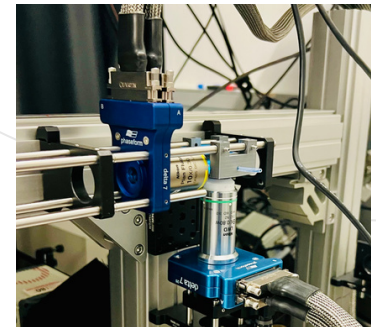

DISCLAIMER

All specifications are preliminary and subject to change without notice. No representation or warranty, either expressed or implied, is made as to the reliability, completeness, or accuracy of this specification sheet.

CONTACT US

Get in touch with us today for a live demo!

Phaseform GmbH
Georges-Köhler-Allee 302
79110 Freiburg i.B.
Germany

www.phaseform.com
info@phaseform.com
[+49 761 216 0800 0](tel:+4976121608000)

Phaseform is supported by

European
Innovation
Council

